

Implementation of K-Nearest Neighbor for Fall Position Detection of Dementia Patients Based Microcontroller

Yulastri ^{a,1*}, Era Madona ^{a,2}, Laxsmy Devy ^{a,3}, Anggara N ^{a,4}, Nur Iksan ^{b,1}

^a Department of Electrical Engineering, Politeknik Negeri Padang, Indonesia

^b School of Digital Science, Universiti Brunei Darussalam, Brunei Darussalam

^{a,1} bundoyulastri@gmail.com, ^{b,1} 22h8914@ubd.edu.bn

* corresponding author

ABSTRACTS

A microcontroller-based detection tool for the presence of patients with dementia has been made using the K-Nearest Neighbor (KNN) method with the help of coordinate points that can be seen via Google Maps, which is based on patient care with a patient-oriented approach. The targets of this research are (a) designing and implementing a fall detection system using the mpu6050 sensor, (b) using the (KNN) method to determine the coordinates of the location of dementia patients using GPS. The research method starts from making a prototype and measuring system performance. The test results on GPS produced an average latitude error of 0.002091% and an average longitude error of 0.000032% in Pauh District, while in Lubuk Kilangan District the average latitude error was 0.002641% and an average longitude error of 0.000150%. The KNN method with the Euclidian distance formula can help supervisors find out the nearest police station to the patient through the coordinate points detected by GPS by taking the smallest value from the comparison of values in the form of degrees between the Pauh police station and the Lubuk Kilangan police station for the patient. Overall the tool can function well.

KEY WORDS

Article history

Received October 10, 2023

Revised October 19, 2023

Accepted December 31, 2023

Keywords

Dementia, K-NN Method, Google Maps, SMS, SIM800L

1. INTRODUCTION

Dementia is a syndrome resulting from brain disease, usually chronic or progressive and involving major functional disorders. The most common type of dementia is Alzheimer's type dementia [1]. Generally, this disease attacks elderly people over the age of 65 years. However, it does not rule out the possibility that young people can also get this disease [2]. There are around 47 million people suffering from Alzheimer's disease in the world [3], and as many as 27 million of them are in Asia [4]. Indonesia is currently experiencing an increase in the number of elderly people from 18 million people (7.56%) in 2010, to 25.9 million people (9.7%) in 2019, and is predicted to continue to increase, where in 2035 it will be 48.2 million people (15.77%) [5].

People with dementia tend to lose insight into their limitations, they are unable to walk without assistance [6]. This condition will make them fall when walking. Sometimes patients with this disease can get lost when walking out of the house and forget the way home [7]. When a patient disappears, it is very difficult for supervisors to find out the position of the patient and contact the police, because they are in a state of urgency so there is a lack of opportunity to provide information to the nearest police who will be contacted. Based on all of this, this research created a tool that can help monitor elderly people, especially elderly people with Alzheimer's type dementia, because if action is not taken quickly, it can cause more severe symptoms such as stroke and even death [8].

Related research has been carried out previously [9]–[11] using SMS notifications [12]–[14] to the family if the patient falls or gets lost and utilizing communication applications and social media to find out the patient's position [15][16]. In this research, a fall detection tool for the elderly was developed to help supervisors find out the location and contact the nearest police station if the patient falls and gets lost using the classification method.

Classification methods are divided into two, namely parametric and nonparametric classification methods. K-Nearest Neighbor (KNN) is a nonparametric classification method. In the process, KNN checks all nearby locations to calculate the closest distance to be classified [17]. KNN has several advantages, namely resilience to training data that has a lot of noise and is effective when the training data is large [18]. The research uses the KNN algorithm because it has strong consistency. When the amount of data approaches infinity [19], the KNN algorithm guarantees a minimal error rate [20]. The aim of this research is to design and implement a fall detection system using the mpu6050 sensor and using the (KNN) method to determine the coordinates of the location of dementia patients using GPS. It is hoped that by making this tool, patients with symptoms of Alzheimer's and dementia will remain healthy and protected in their activities.

2. RESEARCH METHODOLOGY

This research is divided into two, namely developing hardware for fall detection tools and developing the accuracy of patient fall locations at the nearest police station using the KNN classification method.

A. Hardware Design of Fall Detection Device

The design of a fall detection tool for dementia patients in this study is shown in Figure 1. The hardware consists of input, output and control units.

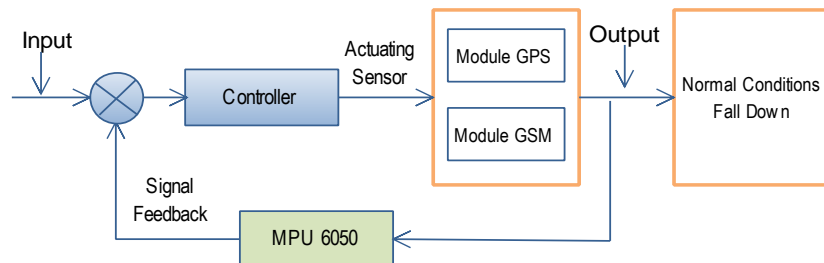

FIG 1. Design of a Fall detection tool for dementia patients

This tool consists of a tilt angle detector using the MPU6050 accelerometer, push button, RTC, DF Player, GSM SIM800L module, battery connected to the 5V and GND pins, Arduino nano functions as a microcontroller as seen in Figure 2.

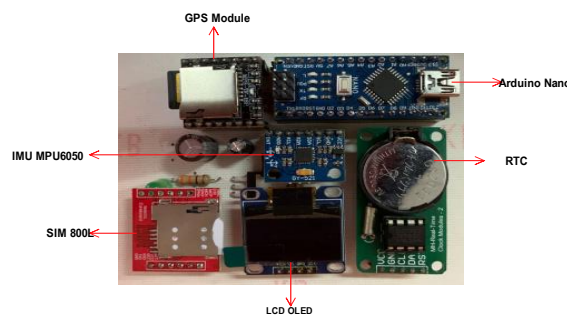

FIG 2. Electronic circuit of a fall detection device

The accelerometer sensor uses an I2C connection (SDA and SCL) where SDA is connected to pin A4 and SCL to pin A5 of the microcontroller. The battery as a mobile voltage source for this system is connected to +5V and GND of the microcontroller and +4V to the SIM800L GSM module. To get a voltage of +4VDC, a DC-DC converter is needed. The panic button is connected to pin 9, the reset button is connected to the RST and GND pins on the microcontroller. Pins 2 and 3 are used as input data output lines to send SMS to the SIM800L. The RX and TX pins are used as output data input lines to activate the DF-Player. The tool created will be placed on the patient's belt. The tool box design can be seen in Figure 3.

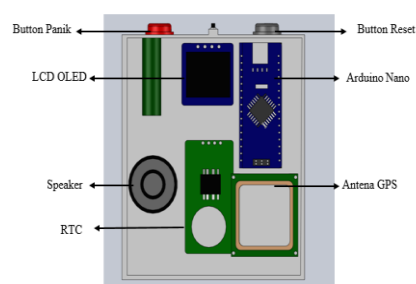

FIG 3. Tool Prototype Design

B. K-Nearest Neighbor

In accordance with the working principle of K-NN, namely finding the shortest distance between the data to be evaluated and its k-nearest neighbors in the training data. The nearest neighbor search technique is

generally carried out using the Euclidean distance formula. Equation (1) below shows the calculation formula for finding the shortest distance using the Euclidean formula [21].

$$Ed = \sqrt{(X_1 - X_2)^2 + (Y_1 - Y_2)^2} \quad (1)$$

Information :

- X_1 = Latitude Training Data
- X_2 = Latitude Test Data
- Y_1 = Longitude Training Data
- Y_2 = Longitude Test Data

To use the k-nearest neighbors algorithm, it is necessary to determine the number of k nearest neighbors that are used to classify new data. The number of ks should be an odd number, for example k=1,2,3 and so on. Determination of the k value is considered based on the amount of existing data and the size of the dimensions formed by the data. The more data there is, the lower the k number chosen should be. However, the larger the data dimensions, the higher the number k chosen should be [22].

C. Software Design

The flowchart of the fall detection monitoring tool for dementia patients is shown in Figure 4.

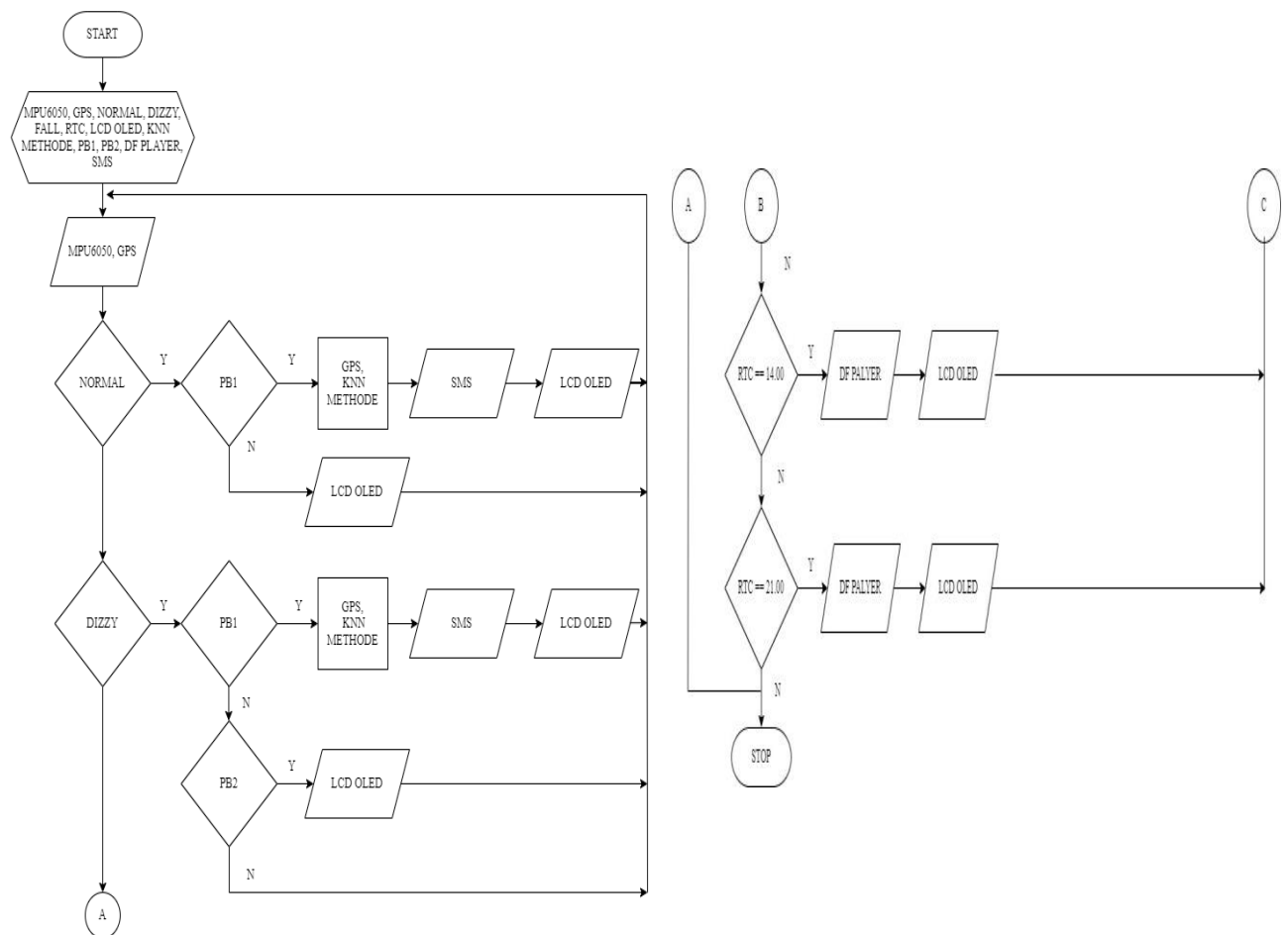

FIG 5. Flowchart of Fall Detection Tool

3. RESULTS AND DISCUSSION

Testing in this research was carried out to determine the system performance and the performance of the KNN classification method for determining the nearest police station if a patient falls and needs help. This device, which is in the form of a bag prototype, is then installed on the patient, which is shown in Figure 5.



FIG 5. Installation of a fall detection device on the body

In system performance testing, we begin by testing the tilt sensor on the accelerometer. We take output data on the X, Y and Z axes to detect the patient's condition. The data taken is based on tilt angles of 0, 30°, 60°, and 90° backwards and to the left, then the sensor data is displayed on the Oled LCD, so that the results are in accordance with Table 1.

TABLE 1. MPU6050 Sensor Test Values

| Conditions of Left and Right Patients | Front & Back Conditions of Patients | test value | | |
|---------------------------------------|-------------------------------------|--------------------|-----------------|-----------------|
| | | X | Y | Z |
| Normal Y = 0°-30° X = 60°-90° | Normal Z = 0°-30° X = 60°-90° | (-9,4) to (7,72) | (-4,4)- (5,0) | (-1,64) to 7,78 |
| dizzy Y = 30°-60° X = 60°-30° | dizzy Z = 30°-60° X = 60°-30° | (-8,65) to (-4,39) | (-7,85) to 8,42 | (-5,53) to 9,2 |
| Fall Y = 60°-90° X = 0°-30° | fall Z = 60°-90° X = 0°-30° | (-5,52) to 0,79 | (-7,85) to 9,79 | <-5.53 or >9,62 |

Based on Table 1, it shows that when the patient is in the left and right positions, the influencing axes are the X axis and Y axis. When the patient is in the front and back positions, the influencing axes are the X axis and Z axis. In normal conditions the left position and the right of the Y axis has a value of 0-30° for the X axis has a value of 60°-90°. Meanwhile, the front and rear positions of the Z axis have a value of 0-30° for the X axis have a value of 60°-90°. In the normal position there is a test value of XYZ, X is worth (-9.4) to (-7.72), Y is worth (-4.4) to 5.0 and Z is worth (-1.64) to d 7.78. In dizziness conditions, the left and right positions of the Y axis are 30°-60° for the X axis are 60°-30°. Meanwhile, the front and rear positions of the Z axis have a value of 30°-60° for the X axis have a value of 60°-90°. In the dizzy position there are test values for XYZ, 9.2. In falling conditions, the left and right positions of the Y axis have a value of 60°-90° for the X axis have a value of 0-30°. Meanwhile, the front and rear positions of the Z axis have a value of 60°-90° for the X axis have a value of 0-30°. In the dizziness position there is a test value of XYZ, Changes in the angle value will affect the accelero sensor value. The greater the change in angle, the greater the value of the accelero sensor. So when the accelero sensor value shows a value > 90 or more, it can be said that the patient has fallen. Next, movement testing is carried out in three positions to detect sudden dizziness experienced by the patient. The test results can be seen in Table 2.

TABLE 2. Movement testing in three positions for detection

| position | Jumlah Percobaan | Dizziness notification via SMS | | Accuracy % | Detection % | |
|------------|------------------|--------------------------------|----|------------|-------------|-------|
| | | Yes | No | | Yes | No |
| | | Sit-Stand | 15 | | 13 | 2 |
| Stand-Walk | 15 | 13 | 2 | 80 | 83.3 | 16.67 |
| Walk-Sit | 15 | 14 | 1 | 90 | | |
| prone | 15 | 14 | 1 | 90 | | |

| | | | | |
|-----------|----|----|---|----|
| Face-down | 15 | 14 | 1 | 90 |
| Total | 75 | 68 | 7 | |

In the seventy-five trial results for testing in Table 2, 83% of the devices were able to detect patients in five activities, with an accuracy rate of around 80% to 90%.

Next, the accuracy of the KNN method test location was tested with 10 data from each sub-district. The test data comes from the coordinates of the Pauh police station and the Lubuk Kilangan police station. The stages carried out in testing GPS as patient location information using the KNN method to determine the nearest police station, (i) taking data from GPS, with certain conditions detected by the accelerometer sensor will automatically send information to the supervisor via SMS notification. taking location data in two areas, namely Pauh sub-district and Lubuk milli ng sub-district, (ii) calculating the euclidean distance value from the coordinates of the location of patients who need help for the two sample police offices, (iii) comparing the results of the euclidean distance value by taking the smallest value from the two PolSek with Delivery output to supervisor. The test results are shown in Table 3 and Table 4.

TABLE 3. Testing of the KNN Method around Pauh District

| Location in Pauh sub-district | GPS | | K-NN | | Klasifikasi |
|---------------------------------|--------------|---------------|-------------------------|-----------------------------------|-------------|
| | Latitude (°) | Longitude (°) | Police station Pauh (°) | Police station Lubuk kilangan (°) | |
| Gerbang Unand | -0.923267 | 100.448440 | 0.02372664 | 0.04077 | Pauh |
| Rumah Makan Tirta | -0.923893 | 100.443840 | 0.01915047 | 0.037208 | Pauh |
| Simpang Kampung Duri | -0.924677 | 100.439147 | 0.01447123 | 0.033725 | Pauh |
| Aciak Mart | -0.925973 | 100.436981 | 0.01198792 | 0.031441 | Pauh |
| Pasar Baru | -0.927779 | 100.430313 | 0.00512734 | 0.026697 | Pauh |
| PolSek Pauh | -0.929813 | 100.425848 | 0.00023693 | 0.023314 | Pauh |
| Komplek Alam Surya Megah | -0.932923 | 100.431358 | 0.00638999 | 0.022569 | Pauh |
| Majid Cupak Tengah | -0.938099 | 100.433441 | 0.01122605 | 0.01968 | Pauh |
| Citra Swalayan | -0.945374 | 100.435924 | 0.01855976 | 0.017235 | LuKi |
| Gadut | -0.943238 | 100.457244 | 0.03423013 | 0.038474 | Pauh |

TABLE 3. Testing of the KNN Method around Lubuk Kilangan District

| Location in Lubuk kilangan sub-district | GPS | | Google Maps | K-NN | (°) |
|---|--------------|---------------|-------------------------|-----------------------------------|------|
| | Latitude (°) | Longitude (°) | Police station Pauh (°) | Police station Lubuk kilangan (°) | |
| Masjid Ubudiyah Karang Putih | - | 100.477333 | 0.05749686 | 0.057542 | LuKi |
| Semen Padang | - | 100.467880 | 0.04899553 | 0.048083 | LuKi |
| SPN | - | 100.462249 | 0.04604762 | 0.042757 | LuKi |
| Lemdadika Pramuka | - | 100.454574 | 0.03790184 | 0.034778 | LuKi |
| Masjid Baitussalam | - | 100.452056 | 0.03252873 | 0.032363 | LuKi |
| Padang Besi | - | 100,452194 | 0.03507904 | 0.032336 | LuKi |
| Pertiwi Cake | - | 100,447486 | 0.03075500 | 0.027630 | LuKi |
| Simpang Gadut | - | 100,443359 | 0.02657573 | 0.023629 | LuKi |
| Bandar Buat | - | 100,436210 | 0.02178739 | 0.016673 | LuKi |
| PolSek Lubuk Kilangan | - | 100,420181 | 0.02309713 | 0.000325 | LuKi |

Based on Table 3, the 1st Euclidean distance data test with latitude: -0.923267° and longitude: 100.448440° . the test location is shown in Figure 6.

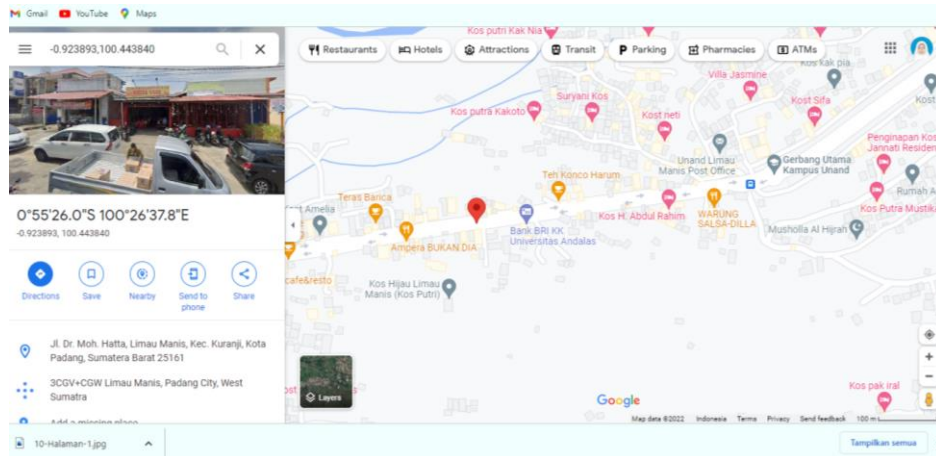

FIG 5. Testing location in Pauh sub-district

Calculate the coordinate values between the Pauh police station and the patient's location

$$Ed1 = \sqrt{((-0.923267) - (-0.929984))^2 + (100.448440 - 100.425684)^2}$$

$$Ed1 = \sqrt{(0.000045^2) + (0.0227560^2)} = \sqrt{0.000518} = 0.02372664$$

Calculate the coordinate values between the Lubuk Kilangan Police Station and the Patient Location

$$Ed2 = \sqrt{((-0.923267) - (-0.952346))^2 + (100.448440 - 100.419864)^2}$$

$$Ed2 = \sqrt{(0.000846^2) + (0.000817^2)} = \sqrt{0.001662} = 0.040770$$

From the calculations it was found that the value of the Pauh police station was smaller than that of the Lubuk Kilangan police station, so that the Pauh police station was closer than the Lubuk Kilangan police station to the patient's location. The test results on SMS notifications using the KNN classification method are shown in Figure 7.

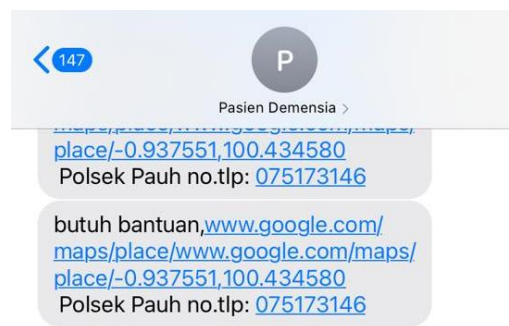

FIG 6. SMS notifications using the KNN classification method

4. CONCLUSIONS

Testing on the tilt sensor on the accelerometer sensor can take several angles for testing, namely 0°-30° with normal conditions producing X-axis values (-9.4) to (-7.72), Y-axis (-4.07) s/d 5.41 and Z axis (-4.58) to 4.81. In conditions of dizziness, the angle of 30°-60° produces values for the X axis (-8.65) to (-4.39), the Y axis (-8.54) to 8.57 and the Z axis (-8.46) to 8.29. In dizziness conditions 60° and 90° produce X-axis values (-5.52) to 0.79, Y-axis (-9.97) to 9.79 and Z-axis (-10.36) to 9.62. Tests on GPS produced an average latitude error of 0.002091% and an average longitude error of 0.000032% in Pauh District, while in Lubuk Kilangan District the average latitude error was 0.002641% and an average longitude error of 0.000150%. The KNN method with the Euclidian distance formula can help supervisors find out the nearest Polsek to the patient through the coordinate points detected by GPS by taking the smallest value from the comparison of values in the form of degrees between the Pauh Police and Lubuk Kilangan Police to the patient.

REFERENCES

- [1] Z. Breijyeh and R. Karaman, "Comprehensive Review on Alzheimer ' s Disease ;," 2020.
- [2] E. Bomasang-Layno and R. Bronsther, "Diagnosis and Treatment of Alzheimer's Disease: An Update," *Delaware J. Public Heal.*, vol. 7, no. 4, 2021, doi: 10.32481/djph.2021.09.009.
- [3] G. Ricci, "Social Aspects of Dementia Prevention from a Worldwide to National Perspective: A Review on the International Situation and the Example of Italy," *Behav. Neurol.*, vol. 2019, 2019, doi: 10.1155/2019/8720904.
- [4] N. T. Aggarwal, M. Tripathi, H. H. Dodge, S. Alladi, and K. J. Anstey, "Trends in Alzheimer's disease and dementia in the Asian-Pacific region," *Int. J. Alzheimers. Dis.*, vol. 2012, 2012, doi: 10.1155/2012/171327.
- [5] L. Heri, M. Cicih, D. Darojad, and N. Agung, "Lansia di era bonus demografi Older person in the era of demographic dividend," *J. Kependud. Indones.*, vol. 17, no. 1, p. 2022, 2022, doi: 10.14203/jki.v17i1.636.
- [6] R. C. Hamdy, J. V Lewis, A. Kinser, A. Depelteau, R. Copeland, and K. Whalen, "Too Many Choices Confuse Patients With Dementia," 2017, doi: 10.1177/2333721417720585.
- [7] E. Bantry and P. Montgomery, "Dementia , walking outdoors and getting lost : incidence , risk factors and consequences from dementia-related police missing-person reports," vol. 19, no. 3, pp. 224–231, 2015.
- [8] A. S. Saber Tehrani *et al.*, "Diagnosing stroke in acute dizziness and vertigo pitfalls and pearls," *Stroke*, vol. 49, no. 3, pp. 788–795, 2018, doi: 10.1161/STROKEAHA.117.016979.
- [9] Y. Lee, H. Yeh, K. H. Kim, and O. Choi, "A real-time fall detection system based on the acceleration sensor of smartphone," *Int. J. Eng. Bus. Manag.*, vol. 10, pp. 1–8, 2018, doi: 10.1177/1847979017750669.
- [10] A. Ishtiaq, Z. Saeed, M. U. Khan, A. Samer, M. Shabbir, and W. Ahmad, "Fall Detection, Wearable Sensors & Artificial Intelligence: A Short Review," *JAREE (Journal Adv. Res. Electr. Eng.*, vol. 6, no. 2, 2022, doi: 10.12962/jaree.v6i2.323.
- [11] L. M. Yee, L. C. Chin, C. Y. Fook, M. B. Dali, S. N. Basah, and L. S. Chee, "Internet of Things (IoT) Fall Detection using Wearable Sensor," *J. Phys. Conf. Ser.*, vol. 1372, no. 1, 2019, doi: 10.1088/1742-6596/1372/1/012048.
- [12] Yulastri, E. Madona, S. Ulfa, and A. Nasution, "Implementation of IMU sensor for Fall Detection in Dementia Syndrome Patients with Location Notification System," *J. Phys. Conf. Ser.*, vol. 2406, no. 1, 2022, doi: 10.1088/1742-6596/2406/1/012010.
- [13] B. Abisoye, J. Kolo, N. Jimoh, O. Abisoye, and L. Ajao, "Development of an SMS-Based Wearable Fall Detection System," *Researchgate.Net*, no. March, 2019, [Online]. Available: https://www.researchgate.net/profile/Ajao_Lukman/publication/331652224_Development_of_an_SMS-Based_Wearable_Fall_Detection_System/links/5c869426299bf16918f85393/Development-of-an-SMS-Based-Wearable-Fall-Detection-System.pdf.
- [14] M. M. Hassan, A. Gumaei, G. Aloï, G. Fortino, and M. Zhou, "A smartphone-enabled fall detection framework for elderly people in connected home healthcare," *IEEE Netw.*, vol. 33, no. 6, pp. 58–63, 2019, doi: 10.1109/MNET.001.1900100.
- [15] H. Isyanto, H. Muchtar, R. Rasma, and A. R. Dinata, "Design of Security System Device for Motorized Vehicles through the Telegram Messenger Application and Updating GPS Locations on Smartphones in Real Time with IoT-based Smart Vehicles," *J. Electr. Technol. UMY*, vol. 6, no. 2, pp. 67–76, 2022, doi: 10.18196/jet.v6i2.16182.
- [16] P. W. A. Sucipto and R. H. Rahmanto, "Telegram Based Mobile Terminal for Body Temperature Data Storage of COVID-19 Patients," *PIKSEL Penelit. Ilmu Komput. Sist. Embed. Log.*, vol. 8, no. 2, pp. 75–82, 2020, doi: 10.33558/piksel.v8i2.2254.
- [17] N. Ali, D. Neagu, and P. Trundle, "Evaluation of k-nearest neighbour classifier performance for heterogeneous data sets," *SN Appl. Sci.*, vol. 1, no. 12, 2019, doi: 10.1007/s42452-019-1356-9.

- [18] T. H. Harahap, S. W. Dachi, and D. N. Sitompul, "K-Nearest Neighbor Algorithm for Predicting Land Sales Price," vol. 3, no. 2, pp. 58–67, 2022.
- [19] Z. Shi, "Improving k-Nearest Neighbors Algorithm for Imbalanced Data Classification," *IOP Conf. Ser. Mater. Sci. Eng.*, vol. 719, no. 1, 2020, doi: 10.1088/1757-899X/719/1/012072.
- [20] V. B. S. Prasath *et al.*, "Distance and Similarity Measures Effect on the Performance of K-Nearest Neighbor Classifier -- A Review," pp. 1–39, 2017, doi: 10.1089/big.2018.0175.
- [21] A. Aditya, B. N. Sari, and T. N. Padilah, "Comparison analysis of Euclidean and Gower distance measures on k-medoids cluster," *J. Teknol. dan Sist. Komput.*, vol. 9, no. 1, pp. 1–7, 2021, doi: 10.14710/jtsiskom.2020.13747.
- [22] J. Lu, W. Qian, S. Li, and R. Cui, "Enhanced k-nearest neighbor for intelligent fault diagnosis of rotating machinery," *Appl. Sci.*, vol. 11, no. 3, pp. 1–15, 2021, doi: 10.3390/app11030919.